

Levers at Work

The lever is a simple machine. It is a stiff bar that pivots on a point called a fulcrum. The bar moves but the fulcrum does not. With a lever, a load is lifted a certain distance when you apply force for another distance. Use the terms in the word box to label the illustrations. Some terms are used more than once.

distance you use load	distance lever uses fulcrum	force
--------------------------	--------------------------------	-------

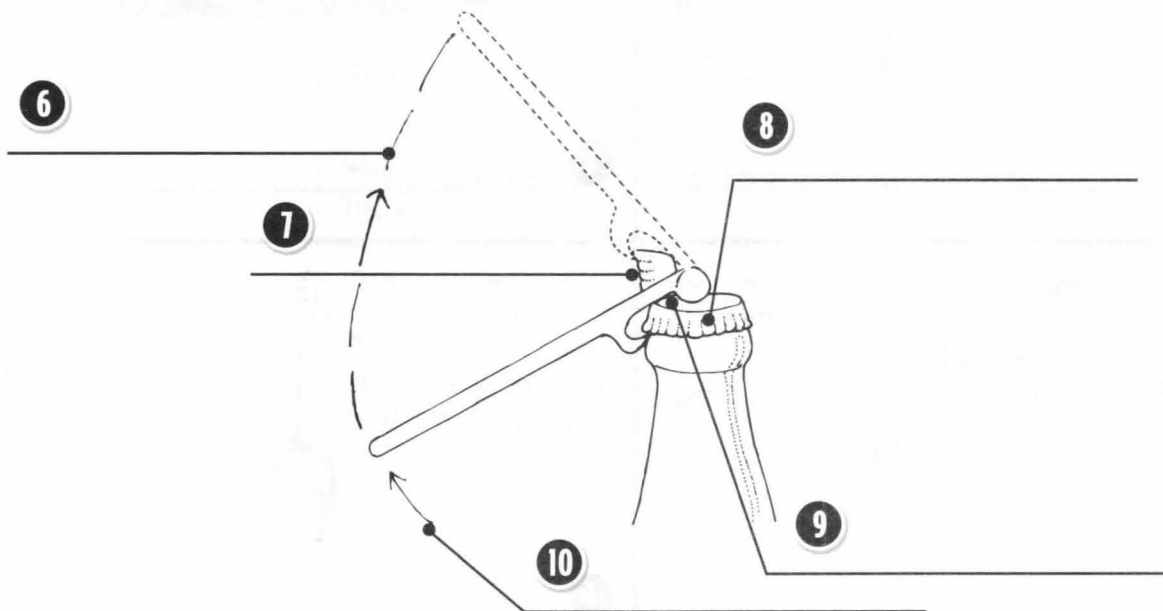
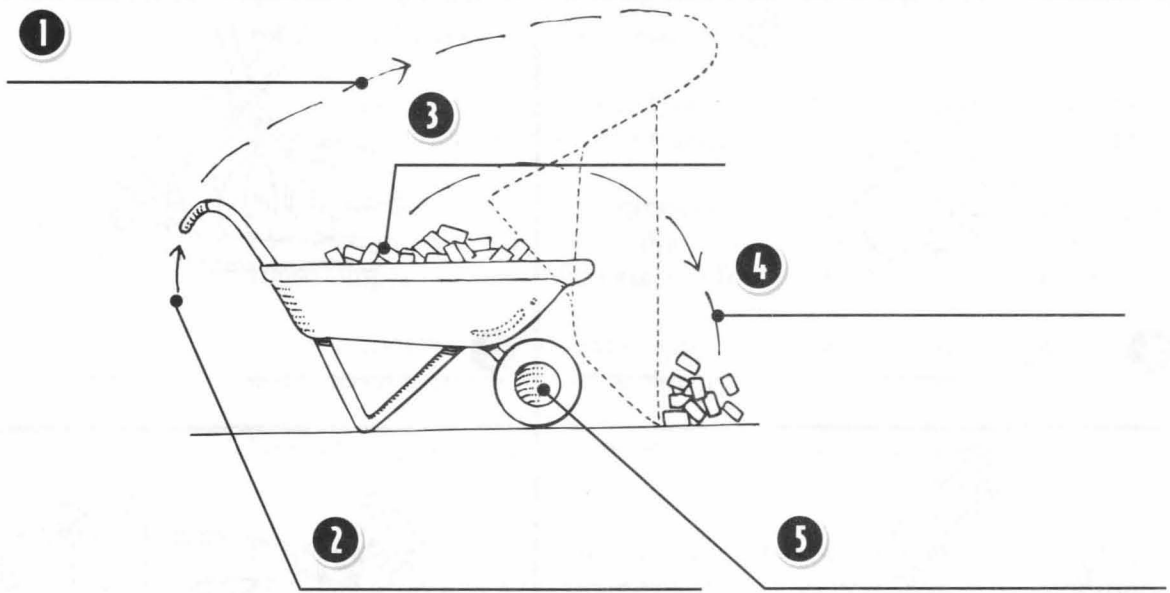

Three Classes of Levers

Levers come in three basic classes. They each have a **fulcrum** or pivot point. Each lever has a **force** put into the lever called an **effort** or input force. Each lever also has a force, called the **load**, which is the object being moved. The type of lever is determined by where the effort and load are placed in relation to the fulcrum. Use the terms in the word box to label each class of lever and the diagrams. Some terms are used more than once.

first class fulcrum	second class load	third class effort
------------------------	----------------------	-----------------------

Type of Lever: _____

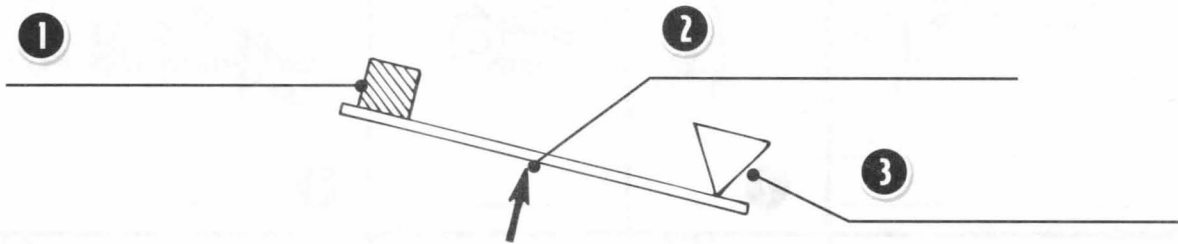

The effort and load are on the same side of the fulcrum, but the effort is closer in.

Type of Lever: _____

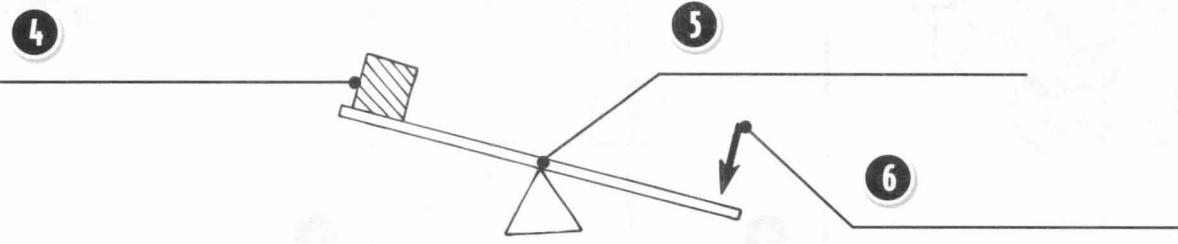

The fulcrum is between the effort and the load.

Type of Lever: _____

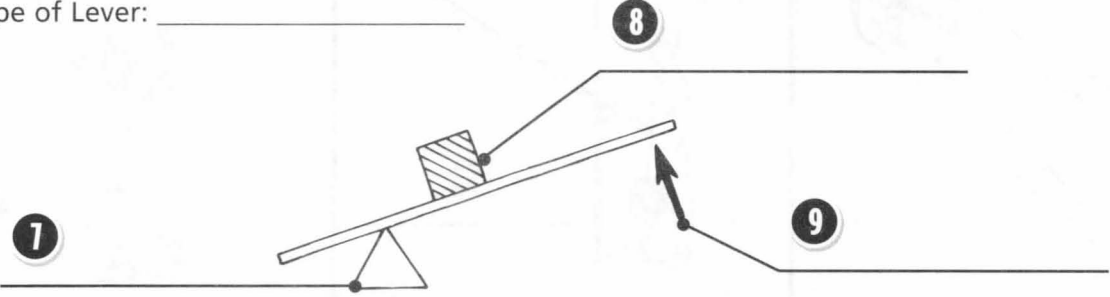







The effort and load are on the same side of the fulcrum, but the effort is farther out.

Classes of Levers

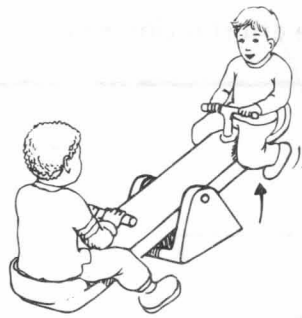
Use the terms in the word box to label each class of lever in the illustrations.

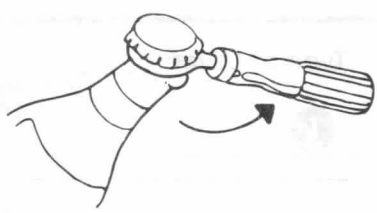
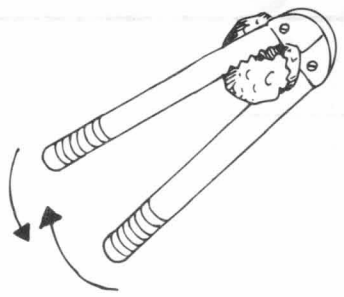
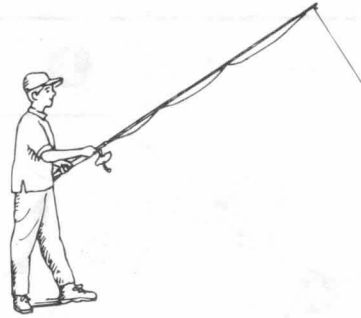
first class second class third class

 <p>1 _____</p>	 <p>2 _____</p>	 <p>3 _____</p>
 <p>4 _____</p>	 <p>5 _____</p>	 <p>6 _____</p>
 <p>7 _____</p>	 <p>8 _____</p>	 <p>9 _____</p>